

AU Instruction for use

# POWERTEX



## Chain Sling Grade 10/100/V

User Manual



## POWERTEX Chain Slings Grade 10/100/V Instruction for use (AU) (Original instructions)

### General:

The work with lifting devices and equipment must be planned, organized, and executed to prevent hazardous situations. In accordance with national statutory regulations lifting devices and equipment must only be used by someone well familiar with the work and having theoretical and practical knowledge of safe use. Before the equipment is used, the instruction manual must be read. It contains important information about how the equipment will work in a safe and correct way. If the equipment is used in accordance with this instruction manual risks and damages can be avoided. Apart from the instruction manual we refer to existing national regulations that may supersede these instructions. This user manual is valid for POWERTEX chain slings used in Australia and made/used in accordance to AS3775.1 & AS3775.2 consisting of Powertex chain and components.

### Use in adverse environments

**Temperature's effect on working load limit (WLL):** Account should be taken to the temperature that can be reached by the chain sling in service. POWERTEX chain slings in grade 10 can be used in temperatures between -40°C and +200°C without reduction of the working load limits.



**If the chain sling reaches temperatures that exceed the allowed temperatures the sling should be discarded or be returned to your distributor for evaluation.**

### Acidic conditions

Chain slings in grade 10/100/V should not be used either immersed in acidic solutions or exposed to acid fumes. Chain slings should for the same reason, not be hot dip galvanized or exposed to electrolytic finishing without permission from the manufacturer.

### Chemical affects

Consult with your distributor in case the slings are to be exposed to chemicals especially combined with high temperatures.

### Hazardous conditions

In particularly hazardous conditions including offshore activities, lifting of a person, and lifting of potentially dangerous loads such as molten metals, corrosive materials or fissile materials, the degree of hazard should be assessed by a competent person and the working load limit adjusted accordingly.

### Before first use

Before first use of the chain sling the user should ensure that:

- a) the sling is precisely as ordered;
- b) the manufacturer's Certificate and User manual is at hand;
- c) the identification and working load limit marking on the sling correspond to the information on the certificate;
- d) full details of the sling are recorded in a register of slings;

### Before each use

Before each use, the chain sling should be inspected for obvious damage or deterioration. If faults are found during this inspection, the procedure given in "Inspection and maintenance" should be followed.

### Choosing the correct chain sling

**Mass of the load:** It is essential that the mass of the load to be lifted is known.

**Method of connection:** A chain sling is usually attached to the load and the lifting machine by means of terminal fittings such as hooks and links. Chains should always be used without twists or knots. Use the shortening hooks to adjust chain legs that needs shortening.

The lifting point should be well seated inside the hook, never on the point or wedged into the opening. The hook should be free to incline in any direction to avoid bending. For the same reason, the master link should be free to incline in any direction on the hook to which it is fitted.

The chain may be passed under or through the load to form a choke hitch or basket hitch. Where it is necessary, due to the danger of the load tilting, to use more than one chain sling leg in a basket hitch, this should preferably be done in conjunction with a lifting beam.

When a chain sling is used in a choke hitch, the chain should be allowed to assume its natural angle and should not be hammered down.

### Chain slings may be attached to the load in several ways

**Straight leg:** In this case lower terminals are connected directly to the attachment points.

Selection of hooks and attachment points should be such that the load is carried in the seat of the hook and tip loading of the hook is avoided. In the case of multi-leg chain slings hook tips should point outwards unless the hooks are specifically designed to be used otherwise.

**Choke hitch:** In this case chain sling legs are passed through or under the load and the lower terminal back hooked or reeved onto the chain. This method can, therefore, be used where no suitable attachment points are available and has the additional advantage that the chain sling legs tend to bind the load together.

Where choke hitch is employed the working load limit (WLL) of the chain sling should be no more than 75% of that marked.

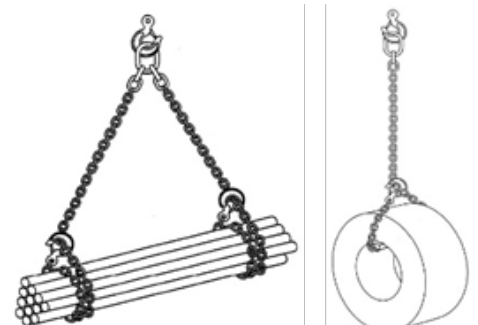

Wrap and choke hitch

Choke hitch

**Basket hitch:** The chain sling is passed through or under the load, the lower terminals are connected directly to the master link or to the hook of the lifting machine. Generally, this method requires two or more chain sling legs and should not be used for lifting loads which are not held together. Where the load geometry permits, a single leg chain sling can be used provided that the chain sling passes through the load directly above the center of gravity of the load.

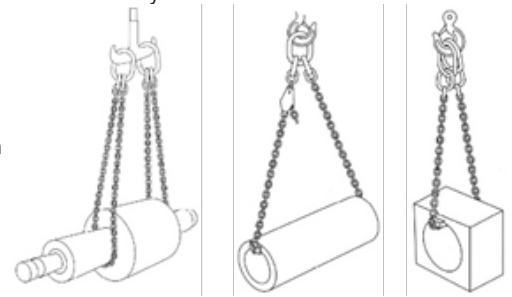

Basket hitch

**Wrap and choke or wrap and basket hitch:** These methods are adaptations of choke hitch and basket hitch, designed to provide extra security of loose bundles and involve taking an extra loop of chain completely around the load.

If two or more chain sling legs are used in a choke hitch or a wrap and choke hitch care should be taken:

- a) if it is important to avoid imparting a torque to the load, to align the chokes; or
- b) if it is important to avoid the load rolling or moving laterally when first lifted, to ensure that at least one leg passes either side of the load.

**Symmetry of loading:** Working load limits (WLL) for chains slings of different dimensions and configurations have been determined on the basis that the loading of the chain sling is symmetrical. This means that when the load is lifted the chain sling legs are symmetrically disposed in plan and subtend the same angles to the vertical. In the case of three leg chain slings, if the legs are not symmetrically disposed in plan the greatest tension will be in the leg where the sum of the plan angles to the adjacent legs is greatest. The same effect will occur in 4 leg chain slings except that the rigidity of the load should also be taken into account.

When a sling is not symmetrically loaded, each leg and lifting point shall be rated to the full load which is to be lifted, or it is considered as an engineered lift and a specialist to assess the lifting arrangement. According to AS3775 multileg slings shall be rated as two legs support the load and the other legs help to balance.

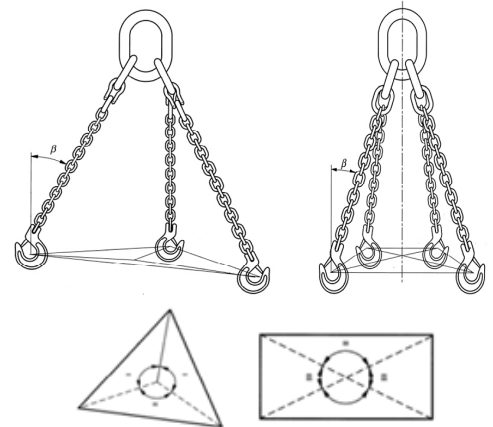

Symmetry of loading

**Center of gravity:** It is assumed that the attachment point of the hook is directly above the center of gravity of the load.

The position of the center of gravity of the load in relation to all attachment points for the chain sling should be established. To lift the load without rotation or overturning following conditions should be met:

- a) For single-leg and single endless slings the attachment point should be vertically above the center of gravity.
  - b) For 2-leg slings the attachment points should be on either side of and above the center of gravity.
- For 3- and 4-leg slings the attachment points should be distributed in a plane around the center of gravity. It is preferable that the distribution should be equal and that the attachment points are above the center of gravity.

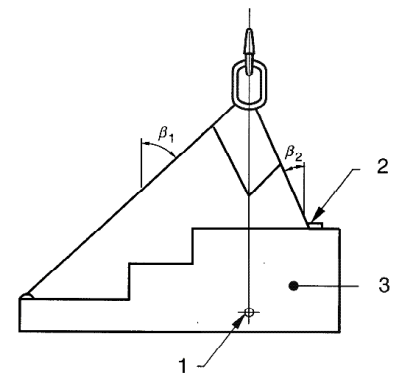

- 1. Centre of gravity
- 2. High tension in this leg
- 3. Load  $P$

## Horizontal forces

All multi-leg slings exert a horizontal component of force (see figure) which increases as the leg angle to the vertical is increased. As a result of this the leg angle to the vertical should never exceed 60°. Care should always be taken to ensure that the load to be moved is able to resist the horizontal component of force, without being damaged.

### How the load of the sling leg changes according to the vertical angle for a 10 ton load.

The red area indicates angles greater than 60° to the vertical for which slings are not intended to be used.

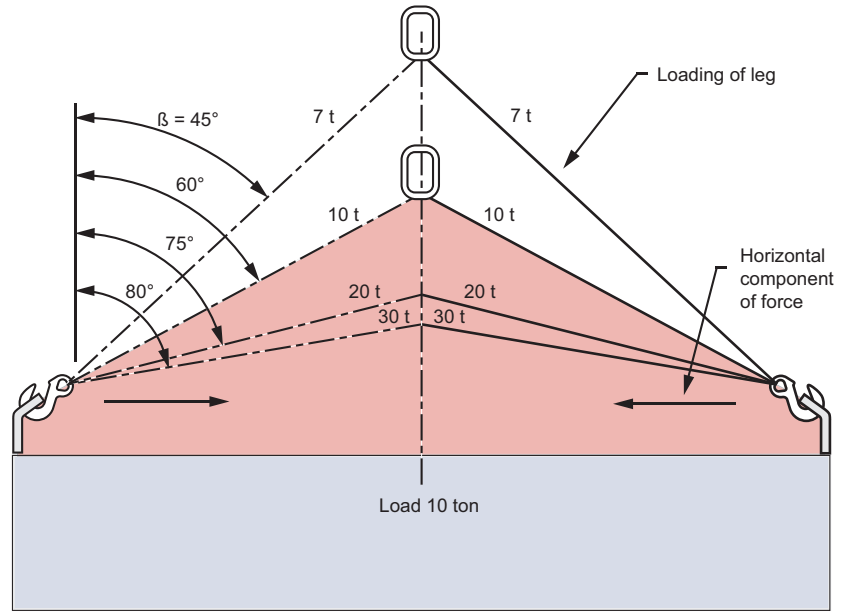

### Reduction of WLL due to sharp edges

It is important to protect the chain links from damages from sharp edges. If proper padding can't be used the WLL of the sling needs to be reduced according to below reduction table.

Edge load effect on WLL	R = larger than 2 x chain Ø	R = larger than chain Ø	R = chain Ø or smaller
Load factor	1 x WLL	0,7 x WLL	0,5 x WLL

### Working load limit (WLL) of the chain sling

Taking into consideration the recommendations and the cumulative effects of de-rating, the method of slinging should be decided, and a suitable chain sling selected so that the mass to be lifted does not exceed the WLL of the sling.

## Load diagram

### Australia WLL - acc. to AS 3775 & AS 3776 Grade 100

Chain	Single	2- 3- or 4-leg*	2- leg slings					
mm	Straight sling or adjustable sling with no deration	Reeved sling	Basket sling Max. 60°	60°	90°	120°	Max. angle 60°	Max. angle 60°
6	1,4	1,1	1,8	2,4	2	1,4	1,8	3,2
7	1,9	1,4	2,5	3,3	2,7	1,9	2,5	4,3
8	2,5	1,9	3,3	4,3	3,5	2,5	3,3	5,6
10	4	3	5,2	6,9	5,6	4	5,2	9
13	6,7	5	8,7	11,6	9,4	6,7	8,7	15,1
16	10	7,5	13	17,3	14,1	10	13	22,5
19	14	10,5	18,2	24,2	19,7	14	18,2	31,5
20	16	12	20,8	27,7	22,6	16	20,8	36
22	19	14,3	24,7	32,9	26,8	19	24,7	42,8
26	26,5	19,9	34,5	45,8	37,4	26,5	34,5	59,6
32	40	30	52	69,2	56,4	40	52	90
<b>Load factor</b>	<b>1</b>	<b>0,75</b>	<b>1,3</b>	<b>1,73</b>	<b>1,41</b>	<b>1</b>	<b>1,3</b>	<b>2,25</b>

### Multi-leg chain slings with less than the full number of legs in use

Occasions may arise when a lift needs to be made using a smaller number of legs than the number of legs in the chain sling. Legs that are not in use should be hooked back to reduce the risk of such legs swinging freely or snagging when the load is moved. Check WLL chart for correct rating.

## Safe use

**Preparation:** Before starting the lift, it should be ensured that the load is free to move and is not bolted down or otherwise obstructed.

Protection may be required where a chain comes into contact with a load in order to protect either the chain or the load or both, since sharp corners of hard material may bend or damage the chain links, or conversely the chain may damage the load because of high contact pressure. Corner protection should be used to prevent such damage.

In order to prevent dangerous swaying of the load and to position it for loading, a tag line is recommended.

When loads are accelerated or decelerated suddenly, dynamic forces occur which increase the stresses in the chain. Such situations, which should be avoided, arise from snatch or shock loading ex. from not taking up the slack chain before starting to lift, or because of the shock from falling load being stopped.

**Safety when lifting:** Hands and other parts of the body should be kept away from the chain sling to prevent injury as the slack is taken up. When ready to lift, the slack should be taken up until the chain is taut. The load should be raised slightly, and a check made that it is secure and assumes the position intended. Lifting personnel must be aware of the risks of swinging and tilting loads. This is especially important with basket or other loose hitches where friction retains the load. Never allow persons or body parts under hanging load. Do not allow persons to ride on the load while the load is being lifted.

**Landing the load:** The landing site should be well prepared. It should be ensured that the ground or floor is of adequate strength to take the load taking account of any voids, ducts, pipes etc. which may be damaged or collapse. It should also be ensured that there is adequate access to the site and that it is clear of any unnecessary obstacles and people. It is preferable to use timber bearers or similar material to avoid trapping the sling or to protect the floor or load or to ensure the stability of the load when landed.

The load should be landed carefully ensuring that hands and feet are kept clear. Care should be taken to avoid trapping the chain sling beneath the load as this may damage the sling. Before allowing the chains to become slack, the load should be checked to ensure that it is properly supported and stable. This is especially important when several loose objects are lifted in basket hitch and choke hitch.

When the load is safely landed the chain sling should be carefully removed to avoid damage or snagging or causing the load to topple over. The load should not be rolled off the sling as this may damage the sling.

**Storage of chain slings:** When not in use chain slings should normally be kept on a properly designed rack. They should not be left lying on the ground where they may be damaged. If the chain slings are to be left suspended from a crane hook, the sling hooks should be engaged in the master link to reduce the risk of sling legs swinging freely or snagging. If it is likely that the slings will be out of use for some time they should be cleaned, dried, and protected from corrosion, e.g. lightly oiled.

## Inspection and maintenance

**Examination:** During service, chain slings are subjected to conditions that may affect their safety. It is necessary, therefore, to ensure, as far as is reasonably practicable, that the sling is safe for continued use.

If the tag or label identifying the chain sling and its working load limit becomes detached and the necessary information is not marked on the master link, or by some other means, the chain sling should be withdrawn from service.

The sling should be withdrawn from service and referred to a competent person for thorough examination if any of the following is observed before each use:

- a) Illegible sling markings i.e. sling identification and/or working load limit.
- b) Upper or lower terminal fitting has deformed.
- c) The chain has been overloaded. If the chain slings have extended if free rotation between the links are missing or if there is a noticeable difference in length between legs in a multi-leg sling, the reason can be that the chain has been overloaded.
- d) Wear by contact with other objects usually occurs on the outside of the straight portions of the links where it is easily seen and measured. Wear between adjoining links is hidden. The chain should be slack and adjoining links rotated to expose the inner end of each link. Inter-link wear (in the bearing points) is tolerated until the mean value of two measured values  $90^\circ$  against each other has been reduced to 90% of the nominal diameter.
- e) Cuts, nicks, gouges, cracks, excessive corrosion, heat discoloration, bent or distorted links or any other defects.
- f) Signs of "opening out" of hooks, i.e. any noticeable increase in the throat openings or any other form of distortion in the lower terminal. The increase in throat opening should not exceed 10% of the nominal value or be such as to allow the safety latch, if fitted, to become disengaged.

**Inspection:** A thorough examination should be carried out of a competent person at intervals not exceeding twelve months. This interval should be less where deemed necessary in the light of service conditions. Records of such examinations should be maintained.

Chain slings should be thoroughly cleaned to be free from oil, dirt and rust prior to examination. Any cleaning method which does not damage the parent metal is acceptable. Methods to avoid are those using acids, overheating, removal of metal or movement of metal which may cover cracks or surface defects.

Adequate lighting should be provided and the chain sling should be examined throughout its length to detect any evidence of wear, distortion or external damage.

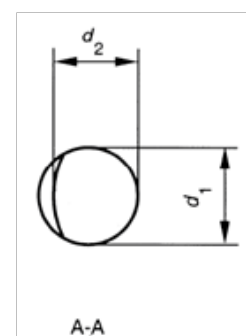
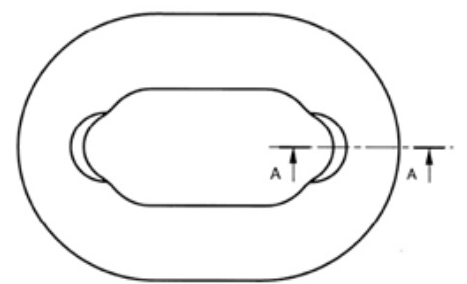

**Repair:** Any replacement component or part of the chain sling should be in accordance with the appropriate standard for that component or part. Use only original spareparts.

If any chain link within the leg of a chain sling is required to be replaced then the whole length of the chain leg should be renewed.

The repair of chain in a welded chain sling should only be carried out by the manufacturer.

Components that are cracked, visibly distorted or twisted, severely corroded or have deposits which cannot be removed should be discarded and replaced.

Minor damage such as nicks and gouges may be removed by careful grinding or filing. The surface should blend smoothly into the adjacent material without abrupt change of section. The complete removal of the damage should not reduce the thickness of the section at that point to less than the manufacturer's specified minimum dimensions or by more than 10% of nominal thickness of the section.

## **End of use/Disposal**



Chain sling shall always be sorted/scrapped as general steel scrap.  
Your POWERTEX distributor will assist you with the disposal, if required.

# User Manuals

You can always find the valid and updated User Manuals on the web.  
The manual is updated continuously and valid only in the latest version.

**NB!** The English version is the Original instruction.

The manual is available as a download under the following link:  
[www.powertex-products.com/manuals](http://www.powertex-products.com/manuals)



## Product compliance and conformity

SCM Citra OY  
Asessorinkatu 3-7  
20780 Kaarina  
Finland  
[www.powertex-products.com](http://www.powertex-products.com)



**POWERTEX**

---

[www.powertex-products.com](http://www.powertex-products.com)